

**PCM MOINEAU**

# Compact Progressive-Cavity Pumps F Series

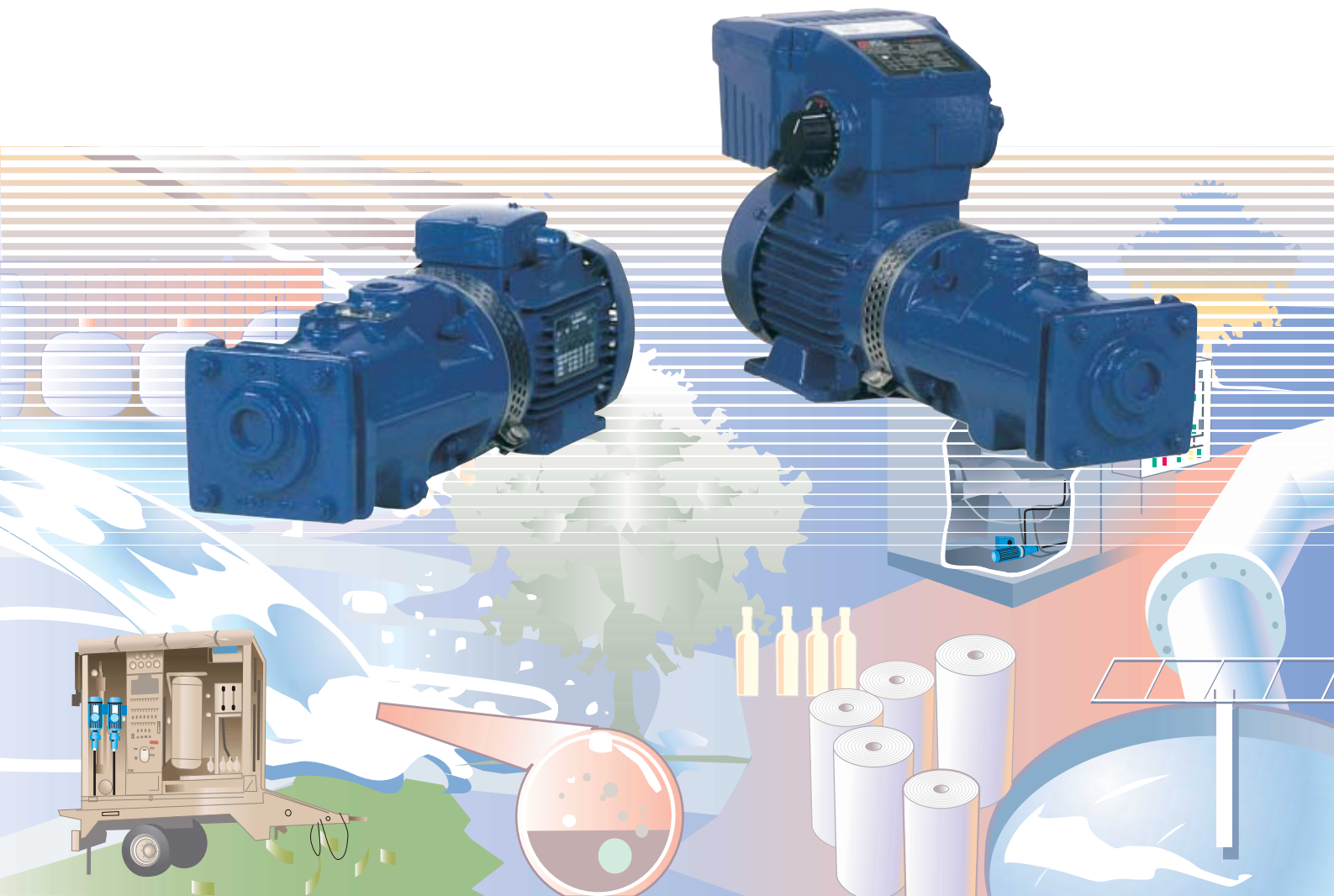

*improving your process*

**PCM Pompes F Series:  
The most compact  
progressive-cavity pump**



Designed specifically for applications calling for compact size combined with excellent integration flexibility, the F series pumps enable users to benefit from the advantages of MOINEAU technology for low price and compact dimensions. Unlike traditional Moineau pumps with their stator bonded into a steel tube, the F series has a floating stator i.e. a stator without a steel armature, attached at one end. The flexibility obtained in this way, combined with an elastic coupling, allows the eccentric rotor to move as if it were floating.

**▶ Benefits**

**Of the Moineau technology:**

- Pump derived directly from the invention by René Moineau, founder of PCM POMPES
- Gentle handling of products
- High suction and self-priming capability
- Constant non-pulsing flow-rate
- Ease of maintenance
- Flow-rate proportional to running speed
- Operation without valves

**Of the F series Moineau pump:**

- Compact size
- Highly simplified drive line without pinjoints
- Very quiet operation
- Simple and rugged cast iron construction
- Particularly easy to maintain
- Versatile

**Characteristics**

- Maximum flow-rate: 3400 l/h
- Maximum pressure: 10 bar
- Maximum continuous operating temperature: 80 °C
- Sterilisation temperature stationary: 140 °C
- Cubic capacity: 1.26 to 37 cm<sup>3</sup>
- Running speed: 240 to 1600 rpm

**Operation**

A Moineau pump is made up of a helical rotor turning inside a helical stator. The stainless steel rotor is machined to a high degree of precision, and the stator is molded in a resilient elastomer. The geometry and the dimensions of these parts are such that when the rotor is inserted into the stator, a double chain of watertight (honeycomb-shaped) cavities is created. When the rotor turns inside the stator, the honeycomb progresses spirally along the axis of the pump without changing either shape or volume. This action transfers the product from the pump intake to the pump discharge.

The F series pump has the special feature of discharging on the drive side. Therefore, the outlet pressure enables the pumped fluid to compress the floating stator against the rotor and ensure gradual tightening during pressure increases.

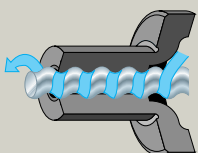

**The F series includes 12 models with a conventional motor or a frequency inverter incorporated into the terminal box so that it can be successfully integrated into processes including fixed or variable flow-rates.**

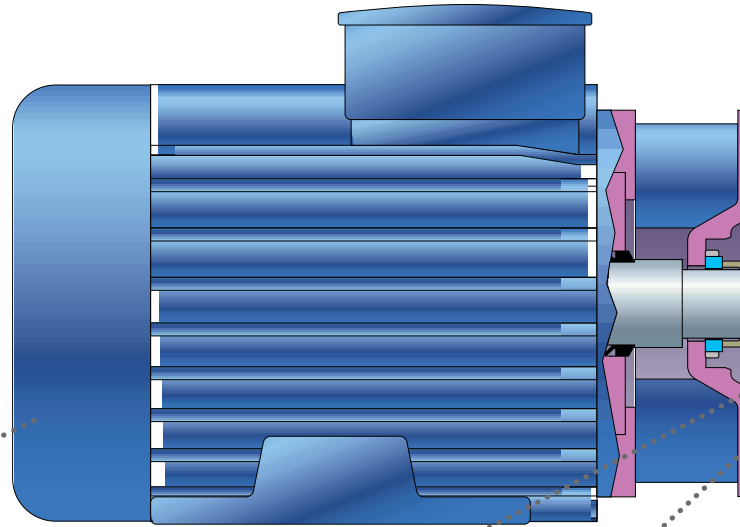

**Drive**

- ▶ Drive by standard flange-mounted motor or flange-mounted variable speed motor with an integral frequency inverter with IP55 protection, tropicalized to 90%, class F.

**Elastic coupling**

- ▶ The traditional drive shaft of the Moineau pump is replaced by a natural rubber or nitrile elastic coupling connecting the drive shaft and the rotor in their rotation. Its flexibility enables it to take up the eccentric movement between the rotor and stator.

**Mechanical seal**

- ▶ Shaft tightness is ensured by a simple carbon/stainless steel mechanical seal or, optionally, silicon carbide/tungsten carbide.

**Adjusting knob**

- ▶ The pump speed is adjusted directly by a large ergonomic and graduated potentiometer.

**Terminal box**

- ▶ Aluminium terminal box with electronic circuit encapsulated in resin and a brass stuffing box to ensure high mechanical resistance to vibration and insensitivity to humidity. An overload indicator, particularly useful at start-up, warns the user of incorrect pump operation, e.g. in the case of overcurrent.

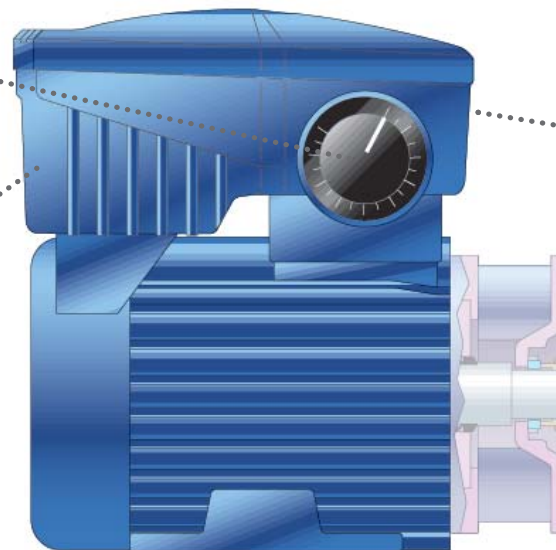

# F Series Construction

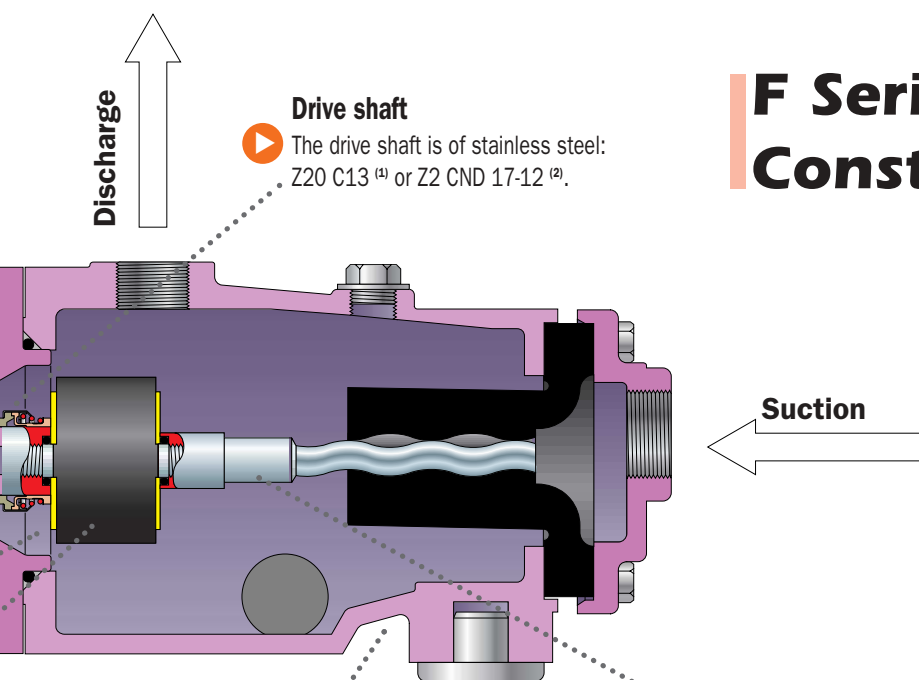

**Drive shaft**  
▶ The drive shaft is of stainless steel: Z20 C13 <sup>(1)</sup> or Z2 CND 17-12 <sup>(2)</sup>.

▶ **Cast iron body**

▶ **Floating rotor-stator**  
Rotor in stainless steel Z20 C13 <sup>(1)</sup> or Z2 CND 17-12 <sup>(2)</sup> if necessary chrome-plated, and floating stator with 1 stage <sup>(3)</sup> of nitrile, hypalon, viton or neoprene.

<sup>(1)</sup> Equivalent to AISI 420

<sup>(2)</sup> Equivalent to AISI 316 L

<sup>(3)</sup> The stage is the length of the stator needed for one cavity to turn through 360° around the pump axis.

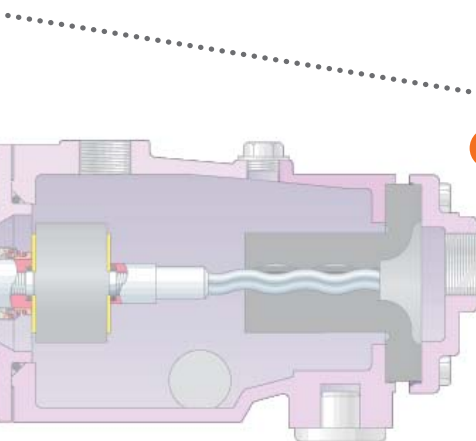

## Frequency inverter integrated into terminal box.

▶ For variable flow-rates, controlled manually or remotely, these frequency inverters offer the best trade-off between price, ease of use and mechanical properties while preserving very good reliability. Pumps equipped in this way dispense with the need for a panel-mounted inverter or an electric cabinet and the resultant cabling and protection. Maintenance is negligible compared to mechanical speed variation systems.

The PCM MVF is more compact, lighter and more economical to use than a mechanical variable speed drive system. Its power factor is close to 1, allowing 100% use of the motor installed power.

## Applicable directives and standards

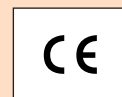

The F series pumps meet the machine directive requirements and its harmonised standards.

## Optional equipment

### By-pass and/or safety valve

To avoid any risks of pump damage in the event of overpressure, it is advisable to protect it with a recirculating by-pass system equipped with a safety valve whose calibration pressure can be set according to the pump discharge pressure.

### Dry running protection

Placed on the suction side, this system ensures that there is product at the inlet of the pump so as to prevent any inadvertent dry operation, which could cause deterioration of the stator or a stop of the process flow.

### Pressure sensor

To better control your process, the installation of a pressure sensor (pressure gauge, pressure switch or analogue sensor) on the pump discharge side is highly recommended. PCM POMPES offers a full range of accessories designed to improve the process operating conditions.

### Automatic level, flow-rate and pressure controls

Depending on the requirements of your installation, PCM can implement solutions to control the pump from your process.

## Electrical and functional specifications for the MV-F version

- Power range from 0.37 to 1,5 kW
- Speed variation range: 1 to 7 (12 to 82 Hz)
- Power supply network: three-phase 400 V +/- 10%.
- Power supply frequency: 50/60Hz +/- 5%.
- Operation from -10 °C to +40 °C
- Starting and stopping by acceleration ramp.
- No adjustment necessary.
- Starting and stopping: either directly by 400V three-phase power supply or by remote contact or by local switch.
- Speed variation: either by local adjusting knob or by 0-10V external setpoint (standard), or by 4-20 mA signal (option).
- Protection: self-protection against under-voltages, over-voltages and short-circuits at the 0/10V inputs and outputs.
- Electrical construction: IP55 protection, 90% tropicalized, class F, sheet metal fan cover

## Options on terminal box

- On-off control.
- RFI filter to prevent electromagnetic interference.
- 4-20 mA setpoint for remote control.
- Display for remote reading.

## Understanding model designation

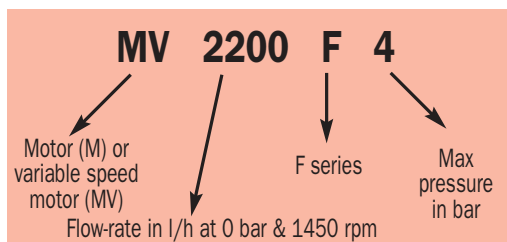

## Performance

The running speeds and pressures indicated on these curves correspond to basic performance levels attained with water at a temperature of 20°C and a 0 bar discharge pressure.

If service conditions differ from this standard, it will be necessary to limit performance according to:

- The characteristics of the product (viscosity, fragility, abrasiveness).
- The application characteristics (operating configuration, discharge pressure, NPSH available).

Model	Motor	Flow-rate at 0 bar (l/h)	Flow-rate at P max. (l/h)	Max pressure (bar)	Speed (rpm)	Motor power (kW)	Phases & Voltage (V)
M110F4	80L	45	20	4	750	0,25	3P 230/400
M110F4	80L	65	35	4	1000	0,25	3P 230/400
M110F4	71L	95	65	4	1500	0,37	3P 230/400
M110F4	80L	95	65	4	1500	0,55	1P 230
M750F4	80L	365	275	4	750	0,25	3P 230/400
M750F4	80L	400	390	4	1000	0,25	3P 230/400
M1200F4	80L	610	500	4	750	0,25	3P 230/400
M750F4	71L	745	615	4	1500	0,37	3P 230/400
M750F4	80L	745	615	4	1500	0,55	1P 230
M1200F4	80L	870	460	4	1000	0,25	3P 230/400
M2200F4	80L	1100	840	4	750	0,25	3P 230/400
M1200F4	71L	1305	540	4	1500	0,37	3P 230/400
M1200F4	80L	1305	540	4	1500	0,55	1P 230
M2200F4	80L	1480	1130	4	1000	0,25	3P 230/400
M3400F4	80L	2170	1370	4	1000	0,55	3P 230/400
M2200F4	71L	2220	1660	4	1500	0,37	3P 230/400
M2200F4	80L	2220	1660	4	1500	0,55	1P 230
M3400F4	80C	3300	2460	4	1500	0,75	1P 230
M3400F4	80L	3300	2460	4	1500	0,75	3P 230/400
M3400F10	90L	3330	2000	10	1500	1,5	3P 230/400
MV110F4	80LVMA	10/105	-/75*	4	250/1600	0,37	3P 400
MV750F4	80LVMA	130/795	55/660	4	250/1600	0,37	3P 400
MV1200F4	80LVMA	260/1380	160/1080	4	250/1600	0,37	3P 400
MV2200F4	80LVMA	340/2360	240/1770	4	250/1600	0,37	3P 400
MV3400F10	100LVMA	540/3750	-/2350*	10	250/1600	1,5	3P 400
MV3400F4	90SVMA	540/4000	-/2670*	4	250/1600	0,75	3P 400

\* No flow at N min for Pmax.

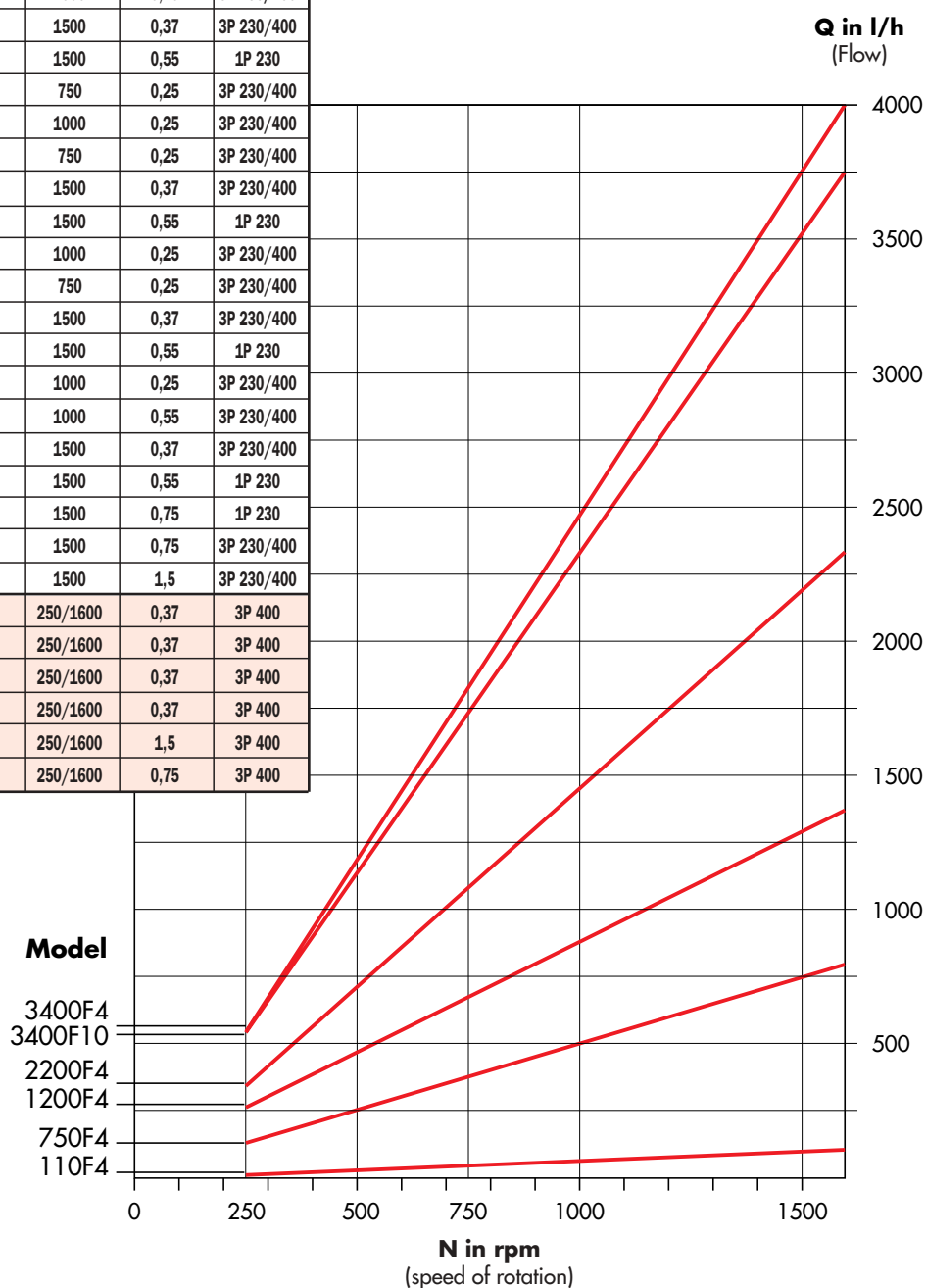

# Sizes F Series

## Cast iron body

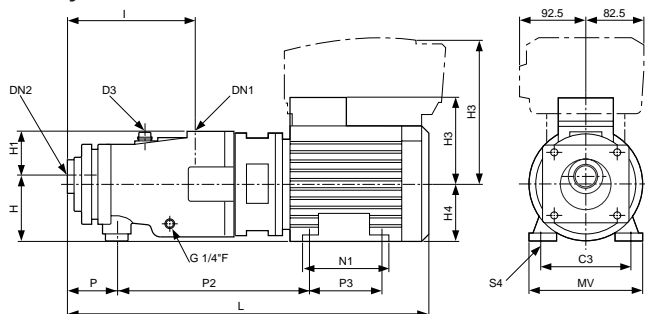

Model	Motor	C3	DN1	DN2	D3	H	H1	H3	H4	I	L	MV	N1	P	P2	P3	S4	Kg
M110F4	71L	112	G3/4"F	G1"F	G3/8"F	81	62	102	71	190±3	464	126	104	70	256	90	7	22
M110F4	80L	125	G3/4"F	G1"F	G3/8"F	90	62	122	80	190±3	506	157	120	70	271	100	9	25
MV110F4	80LVMA	125	G3/4"F	G1"F	G3/8"F	90	62	205	80	190±3	506	157	120	70	271	100	9	28
M750F4	71L	112	G3/4"F	G1"F	G3/8"F	81	62	102	71	190±3	464	126	104	70	256	90	7	22
M750F4	80L	125	G3/4"F	G1"F	G3/8"F	90	62	122	80	190±3	506	157	120	70	271	100	9	25
MV750F4	80LVMA	125	G3/4"F	G1"F	G3/8"F	90	62	205	80	190±3	506	157	120	70	271	100	9	28
M1200F4	71L	112	G3/4"F	G1"F	G3/8"F	81	62	102	71	190±3	464	126	104	70	256	90	7	22
M1200F4	80L	125	G3/4"F	G1"F	G3/8"F	90	62	122	80	190±3	506	157	120	70	271	100	9	25
MV1200F4	80LVMA	125	G3/4"F	G1"F	G3/8"F	90	62	205	80	190±3	506	157	120	70	271	100	9	28
M2200F4	71L	112	G3/4"F	G1"F	G3/8"F	81	62	102	71	190±3	464	126	104	70	256	90	7	22
M2200F4	80L	125	G3/4"F	G1"F	G3/8"F	90	62	122	80	190±3	506	157	120	70	271	100	9	25
MV2200F4	80LVMA	125	G3/4"F	G1"F	G3/8"F	90	62	205	80	190±3	506	157	120	70	271	100	9	28
M3400F4	80L	125	G1"F	G1"1/4F	G3/4"F	95	62	122	80	238±3	562	157	120	80	317	100	9	28
MV3400F4	90SVMA	140	G1"F	G1"1/4F	G3/4"F	105	62	215	90	238±3	585	172	120	80	343	100	10	38
MV3400F10	90L	156	G1"1/2F	G1"1/2F	G3/4"F	112	68	133	90	243±3	643	172	162	85	369	125	11	43
MV3400F10	100LVMA	160	G1"1/2F	G1"1/2F	G3/4"F	122	68	220	100	243±3	668	196	165	85	376	140	12	52

Sizes in mm

# Applications



TMI Photo

In many cases, the F series Moineau pump can be used as a dosing pump. It is an advantageous replacement for traditional dosing units for highly viscous, articulate or abrasive products.

It is compact and rugged, making it particularly suitable for machine or system integration.



Three MV1200F4 pumps with cast iron bodies from a set of 7 waste water treatment plant polymer dosing pumps. These pumps ensure injection proportional to a sludge flow into a dewatering unit with a centrifugal decanter.

M2200F4 pump for feeding salty water jets in a salty rain and spray simulation installation for high voltage insulator tests.



Activity sector	Products transferred or dosed with PCM Moineau F series pumps
Water treatment	Flocculants in waste water treatment plant, deionized water. Polyelectrolytes and various polymers.
Industry	Dosing of additives, Draining of retention tanks, etc...
Mechanical	Machine coolant, oil and cutting oil. Used oils (drainage, machine tool effluents)
Chemicals and energy	Detergent products (detergents, surfactants, sodium hydroxide...) Dyes and inks, phytosanitary products (fungicides, liquid fertilisers) Starch, acrylic glues. Hydrocarbons, domestic and heavy fuel oils (boiler supply). Emulsions (water/oil, water/soap...) Water-based paint, plasticizers, urea/formol resins

This table is not exhaustive but refers to the most general applications. Obviously, there are many more in different fields.

## Services

PCM is constantly striving to work closer with its partners by responding to its customers' needs and offering quality service. All the aspects of LCC are taken into account to provide a better quality product and improve performance.



### Equipment repair and overhaul...

Speed and efficiency. Our technical assistance staff undertake repairs to pumps and regularly overhaul equipment which is already installed.

### Maintenance Contract...

PCM offer maintenance contracts drawn up to suit the requirements and operating conditions of each production unit.

### Spare parts...

Unbeatable delivery. PCM hold a permanent stock of spare parts and accessories so that they can respond to all urgent enquiries.

### Technical assistance...

PCM recommend that their customers take out a maintenance contract to ensure that their pumps provide optimum performance. PCM's technical assistance staff regularly visit installations to perform preventive or corrective maintenance.

### Training...

PCM offer a two-day training course designed to give maintenance personnel a thorough understanding of how to use and maintain positive displacement pumps.

### Pumpexpress...

Availability and reactivity. Complete pumps are available for delivery at any time. This new service allows PCM to meet urgent requests for equipment.

## PCM's range of products includes:

**PCM MOINEAU** The widest range of progressive cavity pumps

**PCM DELASCO** A complete range of adaptable multi-purpose peristaltic pumps

**PCM PROCESS** Feeding and filling systems

**PCM DOSYS** Precision dosing and continuous blending systems

**PCM PRÉCI-POMPE** Electro-mechanical diaphragm and piston dosing pumps

**PCM EQUIPEMENT** Pipeliner-grinders

**PCM MOINEAU OILFIELD** Progressive cavity pumps for crude oil extraction



*improving your process*

HEAD OFFICE

**UNITED STATES**

Tel: +1 713 468 1777  
Fax: +1 713 463 9992  
pcmdelasco@pcmdelasco.com  
www.pcmdelasco.com

**FRANCE**

PCM POMPES, S.A.  
17 rue Ernest Laval - BP 35  
92173 VANVES Cedex  
FRANCE

Tél : +33 (0)1 41 08 15 15  
Fax : +33 (0)1 41 08 15 00  
pcm@pcmpompes.com  
www.pcmpompes.com

**CHINA**

Tel: +86 (0)21 62362521  
Fax: +86 (0)21 62362428  
pcmchina@pcmpompes.com  
www.pcmpompes.com

**UNITED KINGDOM**

Tel: +44 (0)1536 740200  
Fax: +44 (0)1536 740201  
sales@pcmpumps.co.uk  
www.pcmpumps.co.uk

**GERMANY**

Tel: +49 (0)611 60977-0  
Fax: +49 (0)611 60977-20  
info@delasco.de  
www.delasco.de

**TUNISIA**

Tel: +216 71 238 138  
Fax: +216 71 231 713  
pcmtunisie@pcmpompes.com  
www.pcmpompes.com

**THAILAND**

Tel : +66 2 811 8050  
Fax : +66 2 811 9847  
mwitayat@pcmpompes.com  
www.pcmpompes.com